

003L Series
Switch Box



General

003L Series Switch box is designed to mount on Linear Actuators for Diaphragm/Gate/Globe valve.

Installation

003L series switch box is mounted onto the actuator by actuator manufacturer by using suitable brackets.

A. Wiring for mechanical microswitches

Remove the cover after unscrewing 4 screws. Remove the plugs from the cable entries and substitute them with adequate cable glands to ensure the watertight seal.

A wiring diagram is printed onto the PCB inside the switch box adjacent to terminals. Follow it carefully for right connection to your system. Size the cable according to the application.

Solenoids may also be wired through the switch box (applicable when optional Solenoid terminals are provided).

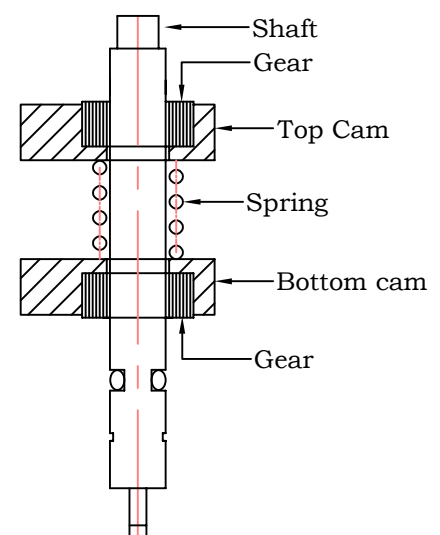

Adjusting limit switches

WARNING: disconnect power before removing cover!

Follow the below procedure for switch setting:

1. Make the Actuator/Valve open by either given air pressure to Open pressure port of actuator or rotate the manual handwheel counter clockwise - For OPEN Switch setting.

Push the YELLOW TOP cam (for open switch) to disengage it from gear, and rotate it until switch trips (Hold the switch roller pressed for proper cam alignment while setting the cam). Re-engage the cam with gear.

2. Make the Actuator/Valve close by either given air pressure to Close pressure port of actuator or rotate the manual handwheel clockwise - For CLOSE Switch setting.

Pull the RED BOTTOM cam (for close switch) to disengage it from gear, and rotate it until switch trips (Hold the switch roller pressed for proper cam alignment while setting the cam). Re-engage the cam with gear.

The information is subject to change without notice.

Shed No.C217, M.T. Sagar,
Industrial Estate,
Gokul Road,
HUBLI-580 030(INDIA).

TeleFax: +91-836-2232118
Mobile: +91-7349132241
e-mail: preorders@kenwoodvalvecontrols.com

B. Wiring for rectangular sensors

Remove the cover after unscrewing 4 screws. Remove the plugs from the cable entries and substitute them with adequate cable glands to ensure the watertight seal.

A wiring diagram is printed onto the PCB inside the switch box adjacent to terminals. Follow it carefully for right connection to your system. Size the cable according to the application.

Solenoids may also be wired through the switch box (applicable when optional Solenoid terminals are provided).

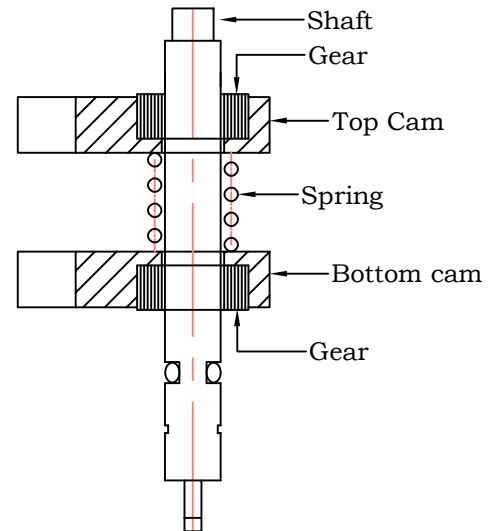

Adjusting sensors

WARNING: disconnect power before removing cover!

Normally the sensors are factory set by valve manufacturer for open/close and does not need any further setting. If required, follow the procedure given below:

1. Make the Actuator/Valve open by either given air pressure to Open pressure port of actuator or rotate the manual handwheel counter clockwise - For OPEN Sensor setting.

Push the YELLOW TOP cam (for open sensor) to disengage it from gear, and rotate it until sensor target is close to the sensor. Re-engage the cam with gear.

2. Make the Actuator/Valve close by either given air pressure to Close pressure port of actuator or rotate the manual handwheel clockwise - For CLOSE Sensor setting.

Pull the RED BOTTOM cam (for close sensor) to disengage it from gear, and rotate it until sensor target is close to the sensor. Re-engage the cam with gear.

The information is subject to change without notice.

Shed No.C217, M.T. Sagar,
Industrial Estate,
Gokul Road,
HUBLI-580 030(INDIA).

TeleFax: +91-836-2232118
Mobile: +91-7349132241
e-mail: preorders@kenwoodvalvecontrols.com

C. Wiring for cylindrical sensors

Remove the cover after unscrewing 4 screws. Remove the plugs from the cable entries and substitute them with adequate cable glands to ensure the watertight seal. Unused cable entry shall be plugged with metal plug to ensure watertight seal.

A wiring diagram is printed onto the PCB inside the switch box adjacent to terminals. Follow it carefully for right connection to your system. Also refer the wiring diagram for a particular switch/sensor. Size the cable according to the application. Solenoid may also be wired through the switch box (applicable when optional Solenoid terminals are provided).

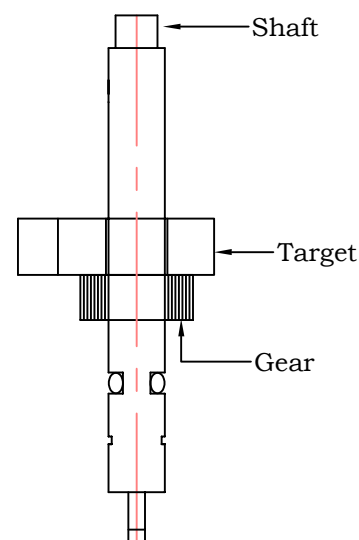
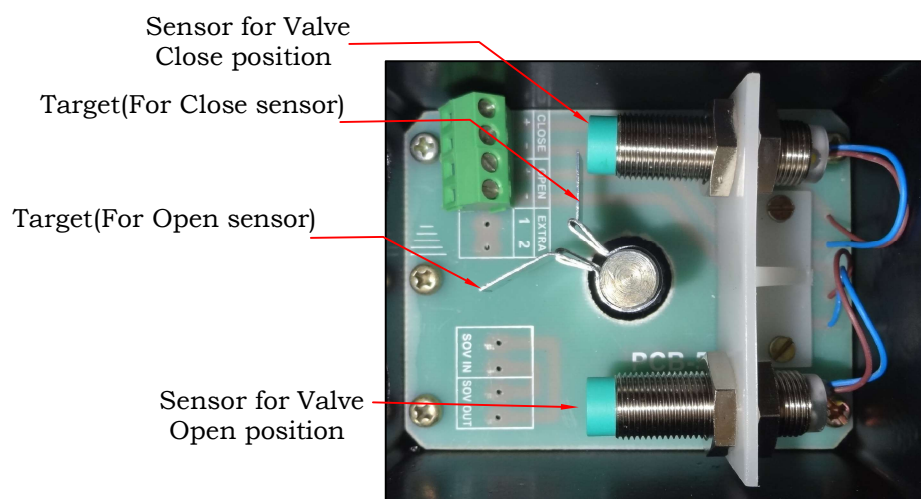

Adjusting sensors

WARNING: disconnect power before removing cover!

To set the switches/sensors follow the procedure given below:

1. Make the Actuator/Valve rotate counter clockwise-For OPEN Switch setting.

Push/rotate the Target (for open sensor) until it comes close to the sensor (either it can touch the sensor or maintain a very small gap of 1mm between sensor and target).

2. Make the Actuator/Valve rotate clockwise-For CLOSE Switch setting. Push/rotate the Target (for close sensor) until it comes close to the sensor (either it can touch the sensor or maintain a very small gap of 1mm between sensor and target).

The information is subject to change without notice.

Shed No.C217,M.T. Sagar,
Industrial Estate,
Gokul Road,
HUBLI-580 030(INDIA).

TeleFax:+91-836-2232118
Mobile:+91-7349132241
e-mail:preorders@kenwoodvalvecontrols.com

KENWOOD VALVE CONTROLS (INDIA) PRIVATE LIMITED

Wiring Diagram

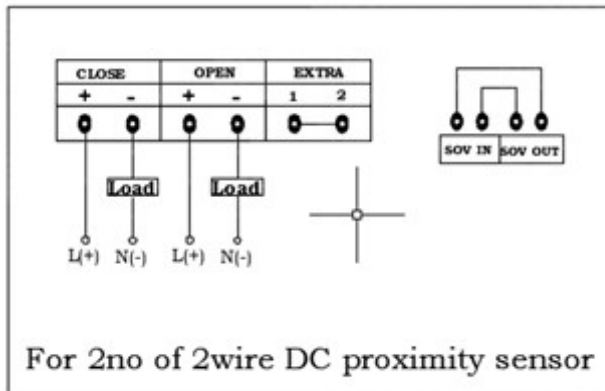
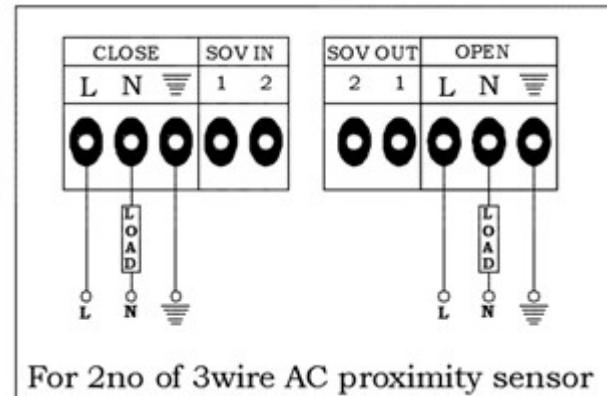
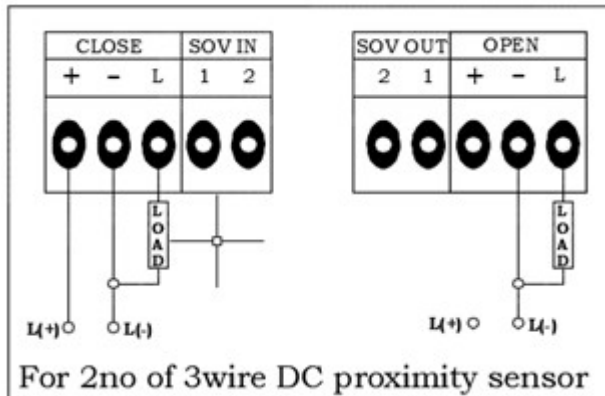
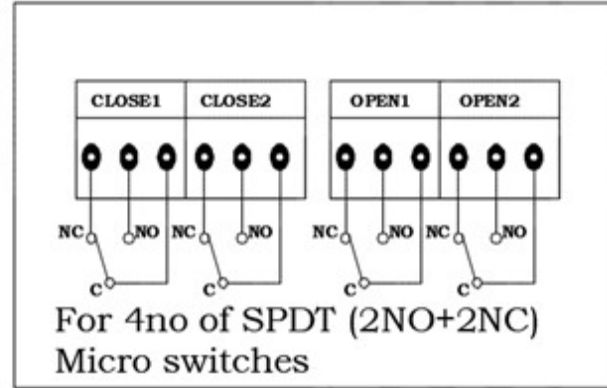
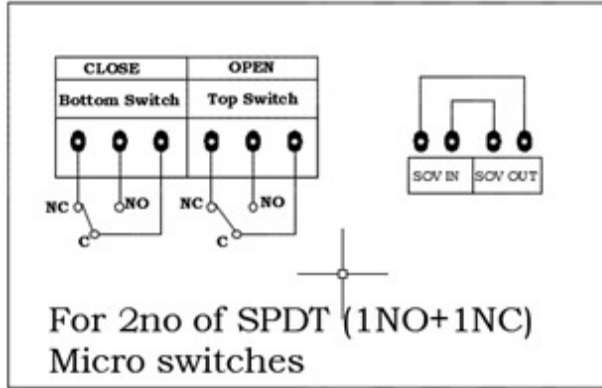

- Note:**
- >>C---Common terminal
 - >>NO---Normally Open terminal
 - >>NC---Normally Close terminal
 - >>SOV IN---From Control room for Solenoid valve connection
 - >>SOV OUT---To Solenoid valve connection
 - >>L---Line
 - >>N---Neutral
 - >>Solenoid terminals are provide only when asked

Rated voltage/current:

Switch /sensor rated voltage and current depends on the switch / sensor used.
Test certificate provided with the product is to be referred for the same.

Shed No.C217,M.T. Sagar,
Industrial Estate,
Gokul Road,
HUBLI-580 030(INDIA).

TeleFax:+91-836-2232118
Mobile:+91-7349132241
e-mail:preorders@kenwoodvalvecontrols.com